

Dimensions (unit:mm)

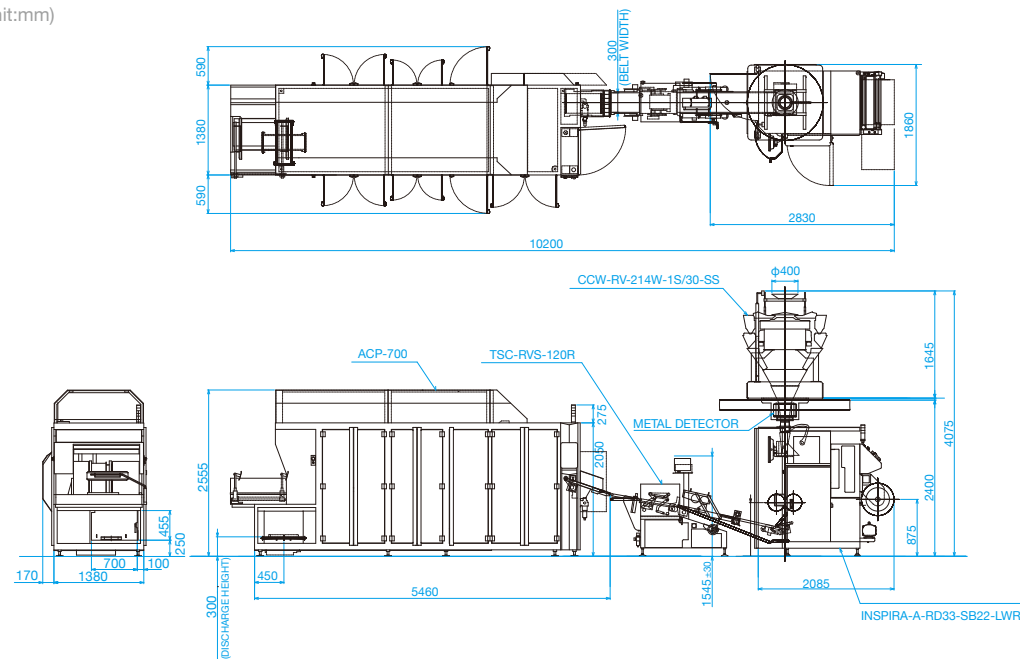

Specifications

Model	ACP-700	
Speed(*1)	10 cases/min, 150 bpm	
Bag Sizes(*2)	Width	108mm~330mm
	Length	Stand Up :120mm~375mm Side Pack :120mm~400mm
Case Sizes(*3)	Thickness	22.5mm~120mm
	Width	300mm~400mm
	Length	400mm~600mm
	Height	125mm~375mm
	Flap Length	150mm~200mm
Tape (*4)	Width	48mm (1.88inch)
	Core Diameter	Max 300mm
Pack Pattern (*5)	Stand-Up Major/Minor, Side-Pack Major/Minor Number of rows: Up to 15, Number of layers Up to 3	
Power Supply	Three Phase 380,400,415,440,480V Electricity Consumption :18.8kVA 23A (480V 50/60Hz)	
Air Consumption	550 L/min(ANR) Maximum (3.4CFM at 70PSI Maximum)	
Machine Weight	Approx. 3.5 t	
Structure	IP-30 (International Standard)	
Surface Treatment	Main Frame: Powder Coated steel Others: Iron – painting, nickel plating, zinc plating, raydent treatment, Aluminium-alumite	
Regulation	CE, RoHS, IEC61131-3 (PLC regulation)	

Design and specifications are subject to change without notice.

(\*1) Running speed depends on the bag and case size, sheet strength, sheet dimension tolerance, film material, pack pattern, case printer, and case turning function on case discharge conveyor.

(\*2) Running condition depends on bag speed, case size, pack pattern, bag weight and product type/volume, ratio of bag width : length : air fill.

(\*3) Case diameter tolerance is ±5mm

(\*4) Tape spec is same spec as Intertape 7100(8100)

(\*5) Max bag count, row number, layer number will rely on bag/case size and speed. Not available to have Stand-Up packing and Side packing in one preset. Not available to put a different count of bags in each row and layer.



ISHIDA CO.,LTD. [www.ishida.com](http://www.ishida.com)

44 Shogoin Sannocho, Sakyo-ku,  
Kyoto, 606-8392, Japan  
Tel: +81 (0)75 751 1618 Fax: +81 (0)75 751 1634



HEAT AND CONTROL, INC. [www.heatandcontrol.com](http://www.heatandcontrol.com)

21121 CABOT BLVD. HAYWARD, CA 94545-1132 USA  
Phone : 1(800)227-5980 1(510)259-0500 Facsimile :1(510)259-0600  
info@heatandcontrol.com



High speed, fully automatic all-in-one case packer

# ACP-700 Series



## ACP-700 series: Experience, more efficient case packing

Ishida now offers the integrated fully automatic case packer, combined with case erector, bag packing/sorting, and case closing/taping. Based on our extensive experience in the snack foods sector around the world, the next generation of case packer, ACP-700, covers a wide range of bag sizes, case sizes, and every pack pattern.

1 All in one case packing system	150 bpm Top industry performance	10 cases/min High performance	3 minutes Fully automatic changeover
30 units Automatic alignment for changeover	500 Preset available for fast changeover	15.3" LCD Intuitive machine interface	330 mm Maximum bag width

### A compact all-in-one system with higher performance from a single supplier

Case erector and case closing mechanism are included to the ACP-700 case packer, which means neither additional conveyor nor signal connections for interfacing many equipment are required. The smallest footprint in the industry enables easy installation for existing production line, and also works efficiently for twin layouts with an offset infeed centerline of 920mm.

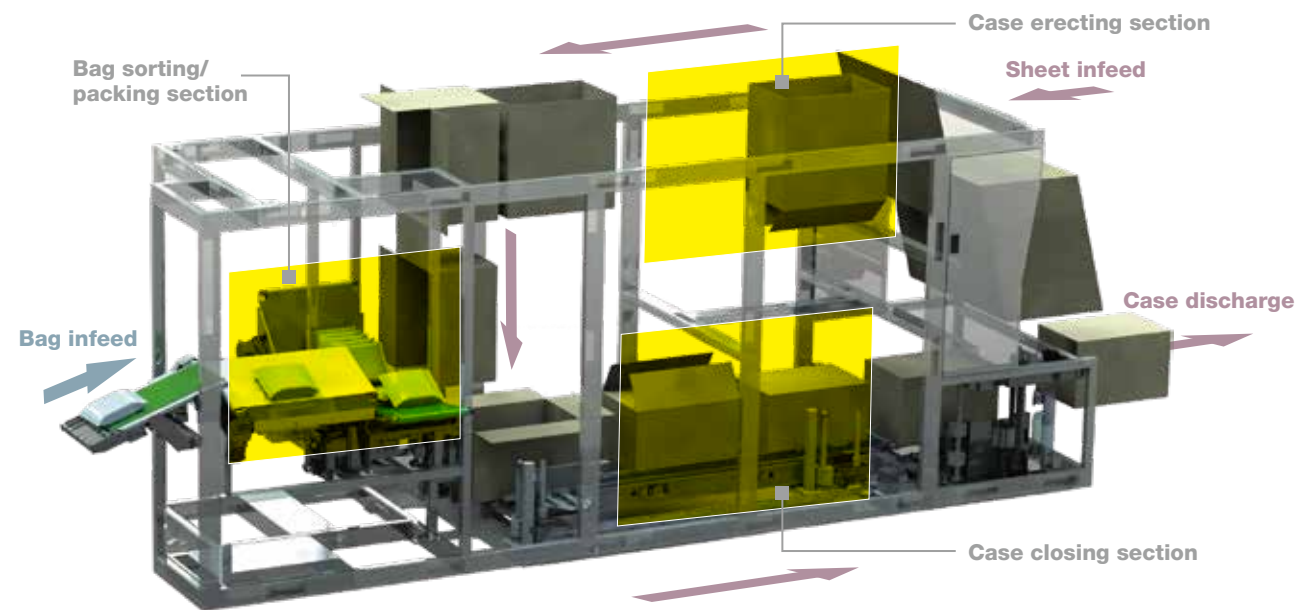

### Fully automatic changeover

By choosing a preset, 30 units are automatically mechanically alignment within three minutes, achieving toolless changeover and zero changeover parts required. This simple and rapid changeover eliminates the need for fine adjustment by skilled operators, reducing the chance of machine fault, resetting, or machine breakage due to human error, and downtime.



### Excellent packing performance for a wide range of bag size and case size

ACP-700, the industry-leading universal case packer, can offer case packing for bag sizes of 108mm to 330mm width for bag types including pillow, side gusset, flat bottom, HEM, can pack different patterns without changing parts. By setting case size and bag size in the HMI, appropriate timing values and mechanical settings are automatically adjusted. Up to 500 presets are available.

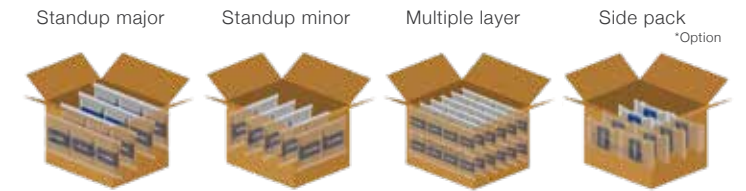

### Easy operation and maintenance

A large 15.3" color HMI provides easy-to-use functionality for changeover, and general operation, and the intuitive screen design reduces the opportunity for human error. The seamless structure with wide opening doors makes access to important units of the case packer quick and easy, with minimal operator effort. There is an alert function for noticing little tape or sheets, and the cylinder operating time check function helps identify the cause of a problem quickly.



### Maximize packing quality by interfacing with seal tester

Ishida TSC seal tester not only checks seal integrity and bag thickness, but it also controls bag posture and bag spaces. ACP-700 automatically optimizes the packing operation based on bag width data sent from the seal tester, which reduces packing error and wasted case consumption. This advanced feed forward control contributes to a stable operation and a sustainable production environment.



### Ishida Total Packaging System

